

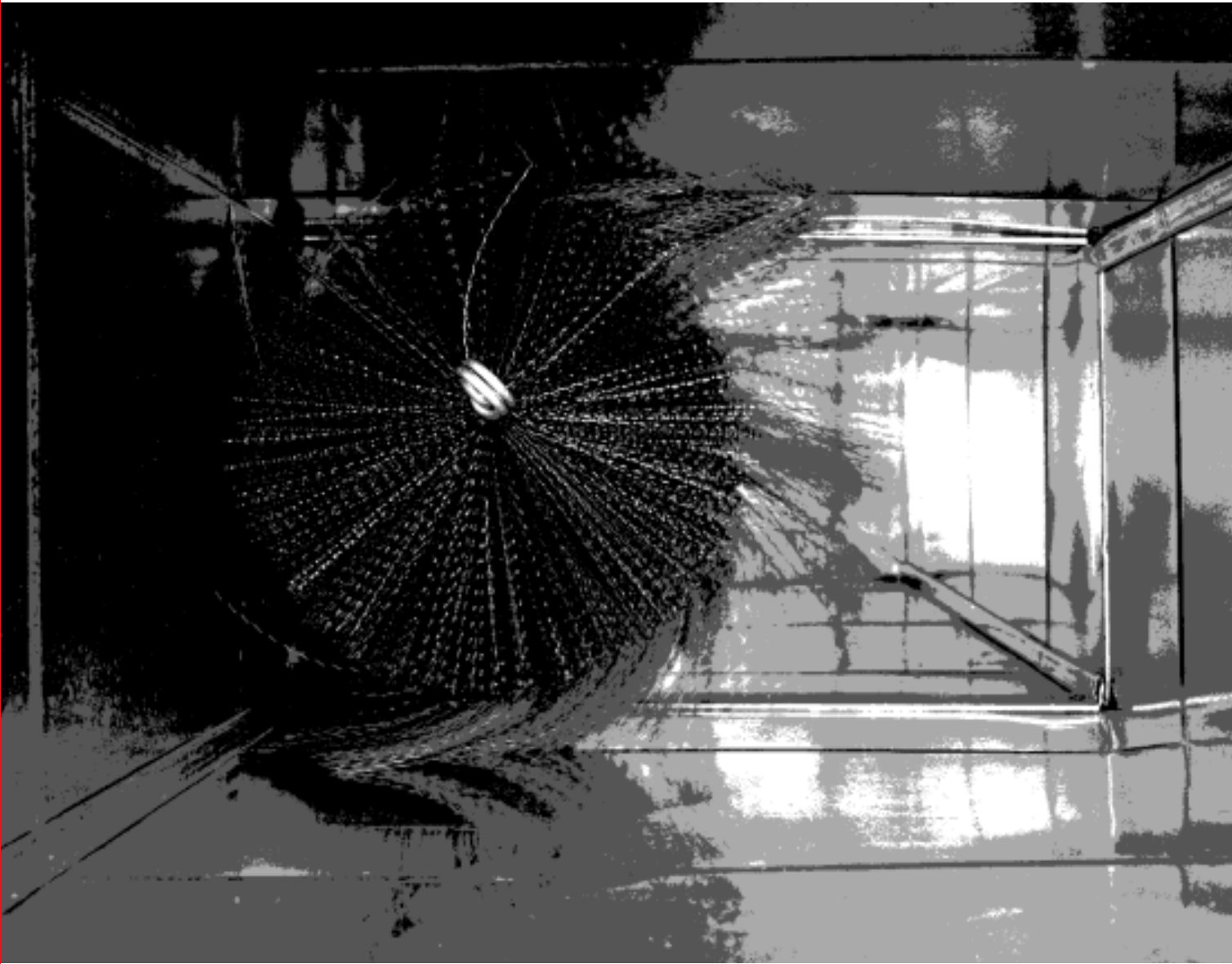

## DUCT-PRO® Tools & Accessories



## Grill-Masks & Dispensers

- The fastest and easiest way to temporarily cover registers and grills. Masks do not come off if negative pressure is temporarily disrupted.
- The dispenser is designed to speed-up the dispensing process. It can conveniently be worn around the neck or waist.

**TO ORDER Grill-Masks:** 8" wide x 185" long (6 rolls/case) #K1-GM-8  
13" wide x 185" long (3 rolls/case) #K1-GM-13  
**Dispenser:** For 8" Grill-Mask #K1-GM-DS-8  
For 13" Grill-Mask #K1-GM-DS13

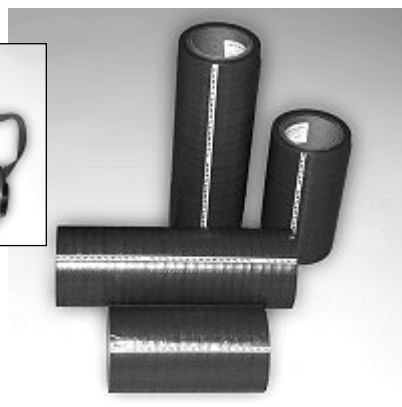

## DUCT-PRO Brushes, Rods & Brush Kits

- Tough nylon bristles are stiff enough for thorough cleaning, but soft enough for use on most fiberglass-lined ducts.
- 3 versatile sizes: 12" (fits through 2.5" hole); 6" & 24" (fit through 5" hole).
- 3' Ploy extension rods with brass locking fittings won't accidentally unscrew.
- Convenient carrying case holds up to ten extension rods.
- Economy Brush Kit includes: 1 12" brush & 1 16" brush & five extension rods.
- Deluxe Brush Kit includes: 1 each, 12", 16", 24" brushes, 10 extension rods & carrying case.

**TO ORDER Deluxe Brush Kit:** #K3-75  
**Economy Brush Kit:** #K3-50

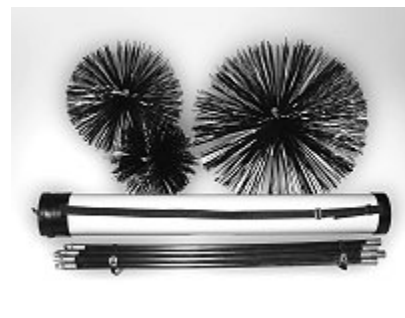

## Cut-Resistant Safety Gloves & Sleeves

- Cut-resistant material and rugged construction give workers hand and arm protection against sharp edges.
- Glove is one-size-fits-all (Mens' Large) and is reversible, fits right or left hand.
- Sleeve fits securely using the adjustable strap.
- Both glove and 21" sleeve are highly cut-resistant, yet extremely flexible and light weight.
- Open weave construction further enhances user comfort.

**TO ORDER Glove:** #K9-698; **21" Sleeve:** #K9-695



## AIRE-BAG Inflatable Zone Bags

- Designed to "zone off" a duct system into smaller, more manageable sections.
- To use: simply insert the bag into the duct and inflate with air through the 3/6" inflation tube.
- The bag will conform to the inside of the duct and forms an excellent seal.
- Heavy PVC resists puncture and abrasion.
- Available in 3 standard sizes: 18", 24" & 36"
- Packed 2 per case.

**TO ORDER 18" x 18":** #K5-218; **24" x 24":** #K5-224; **36" x 36":** #K5-236



## Malco Hole Cutter & Vari-Bit® Hole Saw

- Malco cutter is used with a 3/8" drill to cut metal up to 20 gauge.
- Cuts perfect 2"-12" diameter holes.
- This time-saver will give your job a precise, professional look.
- Vari-Bit is fast & easy to use with 3/8" drill.
- Bores burr-free 1" access holes for inserting the AIRE-SWEEP®
- The Vari-Bit does not require drilling a pilot hole.

**TO ORDER Malco Hole Cutter:** #K1-HC1;  
**Replacement Bit:** #K1-CB; **Replacement Pivot Pin:** #K1-HC1B  
**Vari-Bit 1" Hole Cutter:** #K2-VB2

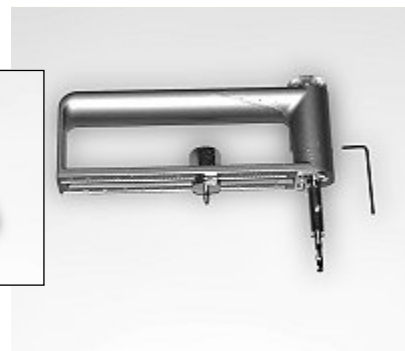

## AIRE-VAC Compressed Air Vacuum

- Converts compressed air into a vacuum, no electricity necessary!
- Maximum suction power is developed by the venturi principle.
- Uses approximately .12 cfm @ 60 psi. Operates on 60-185 psi.
- Lightweight aluminum body.
- Picks up dust, dirt, lint, chips, powders, etc.
- Compact, streamlined unit fits through duct access holes.
- Kit includes: reusable dust bag, 5" nozzle, round duct brush, crevice tool, and 20" extension.

TO ORDER AIRE-VAC: #V80-201

Replacement Filter Bag: #V99-645



## Caplugs® & Zip Screws

- Caplugs snap quickly and easily into 1" AIRE-SWEEP access holes.
- Snug leak-proof fit, but easily removed. NEW soft material.
- Zip Screws require no pilot hole.
- Sharp points and dual threads for maximum penetrating power and fast driving.

TO ORDER Caplugs: Pkg of 1,000 #K4-1000

Pkg of 5,000 #K4-5000

Zip Screws: Pkg of 1,000 #K1-ZS1000

Pkg of 15,000 #K1-ZS15000

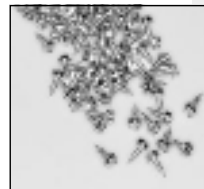

## Video Inspection System for Ducts

- Designed to effectively inspect residential and commercial duct systems to determine contamination levels and sources of airflow problems requiring repair.
- Sharp 5" color LCD monitor that tilts up for easy viewing.
- High resolution, wide angle color camera with a 20 LED lighting array on 35' and cable stores on rotating reel.
- Tough, compact Pelican carrying case is virtually indestructible and weighs just 6.8 lbs.
- VCR adaptor & microphone included.

TO ORDER Video Inspection System: #IS6000



## HVAC Examiner Video Inspection System

- Show customers the 'actual' condition of their heat exchangers.
- Perform duct inspections while customers view the results.
- Detect & identify mold and document your findings.
- High-resolution miniature color video camera on 36" "gooseneck".
- Sharp 5" LCD color monitor that tilts for easy viewing.
- Adjustable camera focus & high/low intensity LED array.
- Tough, compact carrying case is waterproof & lockable.
- Available options: VCR adaptor & microphone.

TO ORDER HVAC Examiner: #IS5000



## Forward & Reverse AIRE-SWEEP Assemblies

- Forward AIRE-SWEEP forces air & debris forward, away from operator.
- Can clear an entire branch run from the register to the main.
- Ideal for limited-access ducts above plaster ceilings or in slabs.
- 5/8" OD hose is flexible enough to maneuver, yet stiff enough not to "curl-back" when air is applied.
- Reverse AIRE-SWEEP nylon nozzle points rearward to push debris back toward the operator. Gives great action inside the duct.
- Three lengths are available.

TO ORDER Forward AIRE-SWEEP 20": #C310K;

Replacement Nozzles: #C311-3

Reverse AIRE-SWEEP 25': #C320K; 35': #C335K;

35' with reinforced hose: #C300-K2

Replacement Nozzles: #C321-3



## Flex-A-Lite Fogger

- The perfect fogger for misting and spraying inside duct work.
- Variable output: 0-18 ounces per minute.
- Extra-long 48" hose enables operator to reach the nozzle without having to lift the tank.
- Easy-fill tank opening is 3.5" in diameter.
- Two-stage fan provides proper air velocity for creating extremely small droplets.

TO ORDER Flex-A-Lite Fogger: #K9-2600



## Chemicals: BBJ Microbiocide® & Oxine® Sanitizer

- BBJ Microbiocide is EPA registered for use in HVAC ductwork
- It is not necessary to evacuate the premises when using.
- Inhibits mold growth.
- Supplied in concentrate form, 3-15 oz bottles/cs. One bottle yields 5 gallons of working solution.
- Oxine-HVAC is EPA Registered for use in HVAC ductwork.
- Supplied in concentrate form with activator, 12-3.25 oz bottles/cs. One bottle yields 1 gallon of working solution.

TO ORDER BBJ Microbiocide: 3-15 oz bottles/cs: #K6-4100-3  
Oxine Sanitizer: 12-3.25 oz bottles /cs: #K6-3014012

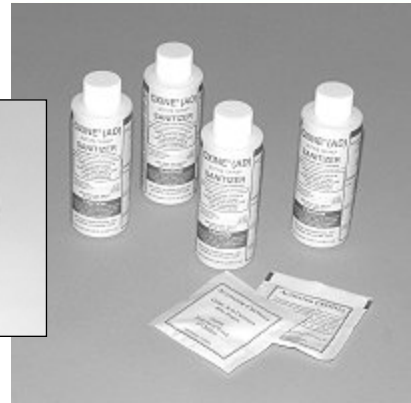

## Dual Inlet Manifold

- Used to combine two HEPA-AIRE power vacuums for maximum airflow on larger jobs.
- Simple to use: attach manifold to ductwork, then attach to 12" inlet flex duct from the two power vacs.
- Constructed of durable, lightweight aircraft aluminum.
- Predrilled to facilitate quick attachment to the ductwork.
- Gasketed for a tight, leak-proof seal.

TO ORDER Dual Inlet Manifold: #K2580

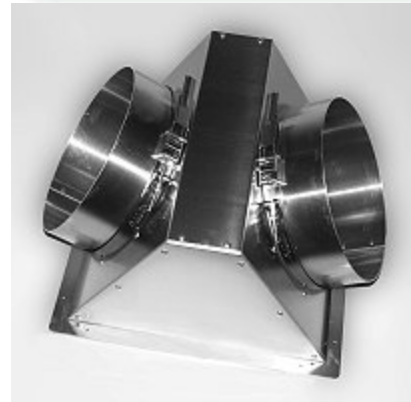

## Wet/Dry HEPA Vacuum

- Stable low-profile design features an easy-emptying tank, low noise level (59 db(A)) and uses quality components throughout.
- Individually tested & certified 99.97% HEPA Filter.
- Power: 1.6 hp; Peak Power: 7.25 hp.
- Air Flow: 120 cfm; Waterlift: 90" w.g.
- Safety Certified.
- Unit weighs 22 lbs. Tank Volume is 8 gallons.
- Tools: 10' hose and chrome wand; floor nozzle, crevice tool and universal nozzle.

TO ORDER Wet/Dry HEPA Vacuum: #V8000WD  
Replacement Bags, 5/cs: #V8040-5  
Replacement HEPA Filter: #V8042



 **ABATEMENT**  
**TECHNOLOGIES**  
Technologically Advanced Air Purification Products

United States: 800.634.9091

Canada: 800.827.6443

[www.abatement.com](http://www.abatement.com)

605 Satellite Blvd., Suite #300, Suwanee, GA 30024

PHONE: 678.889.4200 FAX 678.889.4201