

## 2003 CDC Guidelines For Healthcare Infection Control: How Abatement Technologies Can Help Facilities Meet Recommendations For Preventing Airborne Infections

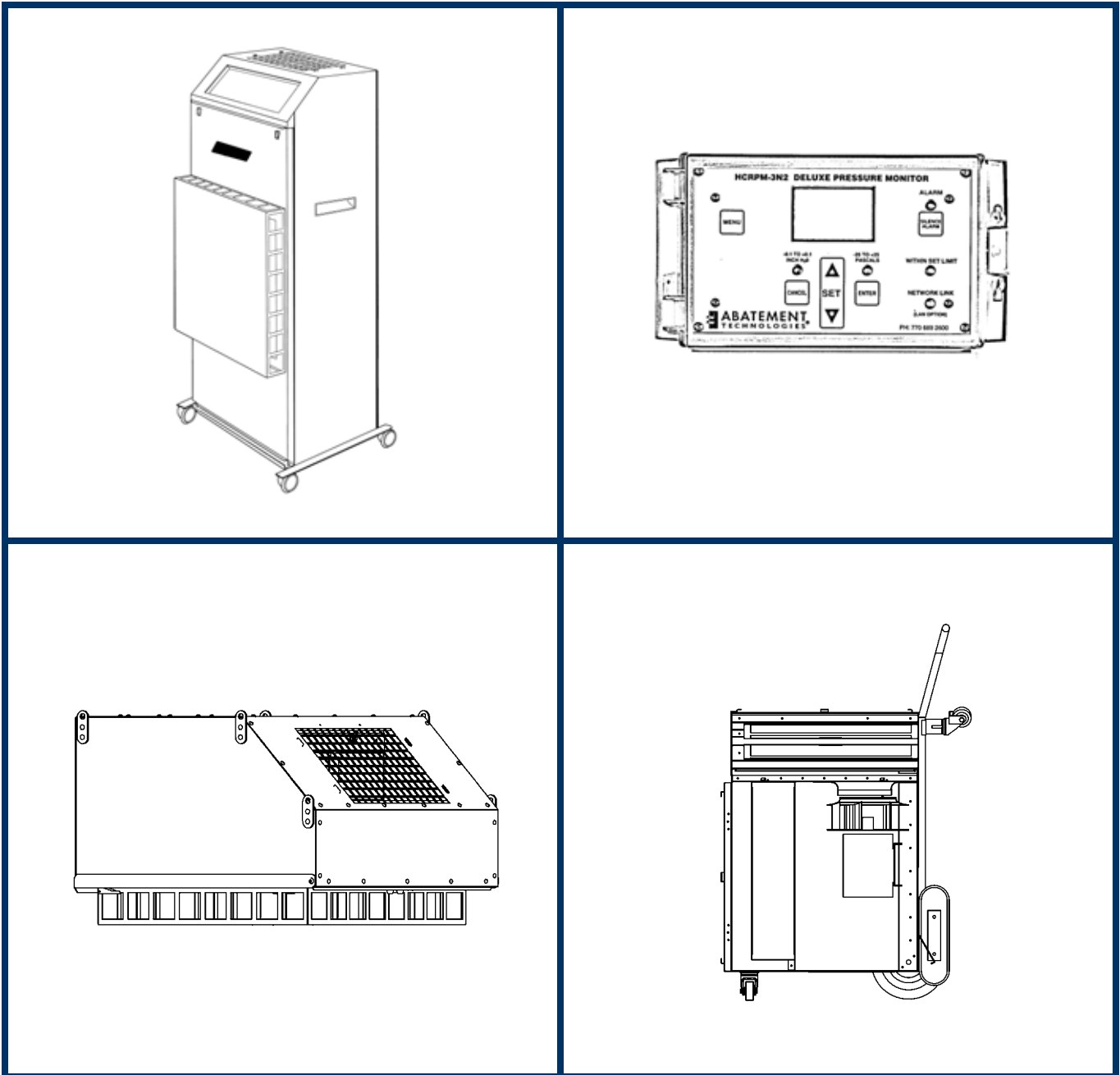

## Meeting the 2003 Infection Control Guidelines

In 2003 the Centers for Disease Control and Prevention and HICPAC (Healthcare Infection Control Practices Advisory Committee) published updated "Guidelines for Infection Control in Health-Care Facilities". HICPAC is a 12-member group that advises CDC on ways to help prevent opportunistic, environmentally related infections in immunocompromised patients. The complete web- text version of this document is available from the CDC's Division of Healthcare Quality Promotion at [http://www.cdc.gov/ncidod/dhqp/gl\\_environinfection.html](http://www.cdc.gov/ncidod/dhqp/gl_environinfection.html).

The guidelines incorporate standards from other organizations, including the American Institute of Architects (AIA) and American Society of Heating, Refrigeration and Air-Conditioning Engineers (ASHRAE), as well as relevant regulations from federal agencies such as FDA, OSHA and EPA, and placed into one of five categories:

- **Category IA:** Strongly recommended for implementation and strongly supported by well-designed experimental, clinical, or epidemiologic studies.
- **Category IB:** Strongly recommended for implementation and supported by certain experimental, clinical, or epidemiologic studies.
- **Category IC:** Required by state or federal regulation, or representing an established association standard.
- **Category II:** Suggested for implementation and supported by suggestive clinical or epidemiologic studies, or a theoretical rationale.
- **Unresolved Issue:** No recommendation is offered.

In addition to acute care facilities, the guidelines are applicable in all venues where health care is provided, including outpatient surgical-centers, urgent care centers, clinics, outpatient dialysis centers, physicians' offices, and skilled nursing facilities. The tables that follow illustrate some of the ways that healthcare facilities utilize Abatement Technologies products to meet certain engineering provisions for:

- Air Handling Systems
- Airborne Infectious Isolation (AII) Rooms
- Protective Environments (PE)
- Operating Rooms & Laser Surgery
- Construction, Renovation, Remediation, Repair, & Demolition.

### Air Handling Systems

CDC Recommendations	Abatement Technologies Solutions
Use portable HEPA filtration units to augment removal of respiratory particles as needed. (Category II)	HEPA-CARE® 99.99% HEPA filtration systems are the perfect choice for patient care areas. HEPA-AIRE® Portable Air Scrubbers (PAS) provide a lower cost alternative for other areas.
Select portable HEPA filter units that can recirculate all or nearly all of the room air and provide the equivalent of 12 or more air changes per hour (ACH). (Category II)	Portable systems with peak airflows of 600cfm up to 4,000cfm can handle a wide range of room sizes. Multiple systems can be employed in one room if necessary.
Portable HEPA filter units previously used in construction zones can be used later in patient-care areas if properly cleaned and decontaminated, and if the filter is replaced or performance verified. (Category II)	HEPA-AIRE PAS can be used effectively in patient-care areas, but are designed primarily for construction applications; the use of HEPA-CARE units in patient-care areas is preferable, with PAS units reserved only for emergency or backup use in patient-care requirements.
When ultraviolet germicidal irradiation (UVGI) is used as a supplemental engineering control for AII areas, install UV fixtures in the return air duct or upper room. (Category II)	The drop ceiling-mounted UV400C module. (See AII – Airborne Infectious Isolation Room section)
Clean ventilation ducts as part of routine HVAC maintenance to ensure optimum performance. (Category II)	Abatement is the leading manufacturer of high-efficiency HEPA filtration systems for source removal duct cleaning.

## Airborne Infectious Isolation Rooms (Negative Pressure Patient Isolation)

CDC Recommendations	Abatement Technologies Solutions
Maintain continuous negative pressure (0.01 inch or 2.5 Pa) in relation to the air pressure in the corridor. (Category IB, IC)	HEPA-CARE patient isolation systems can provide or supplement negative pressure conditions.
Monitor air pressure periodically, preferably daily, with audible manometers or smoke tubes at the door (existing All rooms), or with a permanently installed visual monitoring mechanism. Document results. (Category IB, IC)	Why fool around with messy smoke tubes when HEPA-CARE differential room pressure monitors can continuously measure conditions 24/7? Capabilities include 0.001" accuracy, visual and audio alarms, Johnson Controls compatibility, and a LAN option.
Provide ventilation to ensure 12 or more ACH for new or renovated rooms, and 6 or more ACH for existing rooms. (Category IB, IC)	HEPA-CARE systems can provide up to 12 ACH in rooms up to 3,000 to 3,500 cubic feet in size.
Where supplemental engineering controls for air cleaning are indicated from a risk assessment of the area, install UVGI units in the HVAC exhaust ducts to supplement HEPA filtration, or install UVGI fixtures near the ceiling to irradiate upper room air. (Category II)	Air exhausted from HEPA-CARE units can be ducted into the UV400C UVGI module, which mounts into a 2' x 2' drop ceiling panel and irradiates the air with high-intensity UVGI before it flows into the exhaust duct from the room. This design provides an excellent combination of HEPA plus UVGI.
If a room with an anteroom is not available for VHF (viral hemorrhagic fever) patients, use portable HEPA units to provide additional ACH equivalents & reduce the risk of occupational exposure to airborne infectious materials. (Category II)	Use the HC800F or HC400F portable models.
Place smallpox patients in negative pressure rooms at the onset of their illness, preferably in a room with an anteroom. (Category II)	As with VHF patients the HC800F or HC400F can provide supplemental protection against airborne infectious materials.
Direct exhaust from All rooms to the outside, away from air intakes. If this is not practical, air from the room can be recirculated after passing through a HEPA filter. (Category IC)	The HC400C or HC800C models provide 99.99% HEPA filtration without adding load to the facility HVAC system, and can be supplemented with UVGI, whether the exhaust air is ducted outdoors or back into the HVAC system.
Use All rooms for patients with or suspected of having an airborne infection & use cough-inducing procedures, or use an enclosed booth that is engineered to provide: 12 or more ACH; 0.01 in. (2.5 Pa) negative pressure; and air exhausted outside away from air intakes or traffic, or recirculated after HEPA filtration. (Category IB, IC)	HEPA-CARE models can be used to place an entire room or an enclosed booth under negative pressure & to meet the requirements for ACH and HEPA filtration.

## Operating Rooms & Laser Surgery

CDC Recommendations	Abatement Technologies Solutions
Maintain positive pressure with respect to corridors and adjacent areas (Category IB, IC). Maintain 15 ACH or more, of which 3 or more ACH should be fresh air. (IC)	The HC400C-PP is ideally suited for enhancing ACH in positive pressure environments, and all other models can be set up for positive pressure as well.
Use portable HEPA filtration units for supplemental air cleaning during intubation and extubation. Position the room units so that all room air passes through the filter; switch off the unit during the procedure. (Category II)	With features like a gel-seal HEPA filter tested and certified to a minimum efficiency of 99.99% @ 0.3 microns, the HC800F model HEPA-CARE air filtration system is the perfect portable choice for these applications.
Use a mechanical smoke evacuation system with a high efficiency filter to manage the generation of large amounts of laser plume when ablating tissue infected with human papilloma virus (HPV) or performing procedures on a patient with extrapulmonary TB. (Category II)	Any of the HEPA-CARE models are ideally suited for these applications, especially the portable models, which can enable the filtration unit to be placed as close to the patient as may be required. HEPA-AIRE PAS units can also be used for this application.

## Protective Environments (Positive Pressure Patient Isolation)

CDC Recommendations	Abatement Technologies Solutions
Minimize exposure of immunocompromised patients (e.g., solid organ transplant patients or allogeneic neutropenic patients) to activities that may cause aerosolization of fungal spores (e.g., vacuuming, disruption of ceiling tiles). (Category IB)	HEPA-CARE portable systems can be used to capture airborne contaminants that may be disturbed and aerosolized during these activities, or to maintain positive pressure within an enclosed tent.
Install central or point-of-use HEPA filters for supply air (incoming air in new PE units). (Category IB, IC)	Install the HC400C-PP ceiling/duct mounted unit into a drop ceiling to filter incoming supply air. Its internal motor/blower assembly overcomes the added resistance of the HEPA filter, so there is no added load to the central HVAC system.
Maintain positive room pressure (0.01 in. or more) in relation to the corridor. (Category IB, IC)	The ceiling-mounted HEPA-CARE HC400C-PP model is designed specifically for positive-pressure patient isolation. Other models can also be configured for this application.
Ventilate new PE rooms to provide 12 or more ACH (Category IC) If air supply systems are not optimal (to provide necessary pressure relationships and ACH), use portable HEPA filtration units until rooms with optimum air-handling systems become available. (Category II)	HEPA-CARE HC800F or HC400F isolation room systems can supplement existing HVAC ventilation. HEPA-AIRE Portable Air Scrubbers can also be used to meet emergency or short-term requirements.
To protect immunocompromised patients with an airborne infectious disease (e.g., acute VZV infection or tuberculosis): ensure that the patient's room is designed to provide negative pressure; use an anteroom to ensure appropriate air balance relationships, and either provide independent exhaust of contaminated air to the outside, or <u>place a HEPA filter in the exhaust duct if return air must be recirculated</u> .	If return air must be recirculated, HEPA-CARE HC400C or HC800C models can be mounted into the drop ceiling to replace the return air grill. This ensures that the return air is HEPA filtered without adding any load to the central HVAC system.
If an anteroom is not available, place the patient in All and use portable HEPA filtration units to enhance filtration of spores in the room.	The HC800F and HC400F models are perfect for these situations. HEPA-AIRE PAS can also be used to meet temporary requirements.
Monitor at least daily with permanently installed visual means in new or renovated construction, or using other visual methods in existing PE units. Document the monitoring results. (Category IC)	Install a wall-mounted HCRPM-3N2K electronic pressure monitor for 24/7 real time monitoring and documentation, including central monitoring capability and Johnson Controls MetaSys 3N2 or LAN options.

## Construction, Renovation, Remediation, Repair & Demolition Areas

CDC Recommendations	Abatement Technologies Solutions
Create and maintain negative air pressure in work zones adjacent to patient-care areas and ensure that engineering controls are maintained. (Category IB)	HEPA-AIRE Portable Air Scrubbers can create or enhance negative pressure levels, and continuously filter the air within the enclosure.
Monitor negative airflow inside rigid barriers and review documentation to verify that pressure differentials were appropriate for their settings. (Category IB, IC)	Choose between the portable HCPDPM model and the wall-mounted HCRPM-3N2 model.
For major repairs in patient areas that include removal of ceiling tiles & disruption of the space above the false ceiling use plastic sheets or prefabricated plastic containment units to control dust. (Category IB)	Abatement Technologies offers several prefabricated plastic containment product options.
Use a negative pressure containment system within this enclosure to remove dust; and either pass air through a portable HEPA unit capable of filtration rates ranging from 300-800cfm, or exhaust air directly to the outside. (Category IB)	The airflow of the HEPA-AIRE PAS600, (up to 600 cubic feet per minute), is more than sufficient to cleansing the air and maintain negative pressure in most enclosures. For even larger enclosures users can select the PAS1200 (up to 900cfm), or use the PAS1800 and PAS2400 models at the low speed setting.

All illustrations and specifications contained in this brochure are based on the latest product information available at the time of printing. Abatement Technologies reserves the right to: (1) make changes at any time, without notice, to product designs, specifications, materials and colors, (2) introduce new products to the marketplace, and (3) discontinue products as it sees fit.